



An Oshkosh Corporation Company

Supplemental Operation and Safety Manual

Keep this manual with the machine at all times.

Supplemental Manual for Cribbing of Approved JLG Products



3128168

May 3, 2022

FOREWORD

This manual is a very important tool! Keep it with the machine at all times.

The purpose of this manual is to provide owners, users, operators, lessors, and lessees with the precautions and operating procedures essential for the safe and proper machine operation for its intended purpose.

Due to continuous product improvements, JLG Industries, Inc. reserves the right to make specification changes without prior notification. Contact JLG Industries, Inc. for updated information.

SAFETY ALERT SYMBOLS AND SAFETY SIGNAL WORDS



This is the Safety Alert Symbol. It is used to alert you to the potential personal injury hazards. Obey all safety messages that follow this symbol to avoid possible injury or death.

⚠ DANGER

INDICATES AN IMMINENTLY HAZARDOUS SITUATION. IF NOT AVOIDED, WILL RESULT IN SERIOUS INJURY OR DEATH. THIS DECAL WILL HAVE A RED BACKGROUND.

⚠ WARNING

INDICATES A POTENTIALITY HAZARDOUS SITUATION. IF NOT AVOIDED, COULD RESULT IN SERIOUS INJURY OR DEATH. THIS DECAL WILL HAVE AN ORANGE BACKGROUND.

⚠ CAUTION

INDICATES A POTENTIALITY HAZARDOUS SITUATION. IF NOT AVOIDED, MAY RESULT IN MINOR OR MODERATE INJURY. IT MAY ALSO ALERT AGAINST UNSAFE PRACTICES. THIS DECAL WILL HAVE A YELLOW BACKGROUND.

NOTICE

INDICATES INFORMATION OR A COMPANY POLICY THAT RELATES DIRECTLY OR INDIRECTLY TO THE SAFETY OF PERSONNEL OR PROTECTION OF PROPERTY.

⚠ WARNING

THIS PRODUCT MUST COMPLY WITH ALL SAFETY RELATED BULLETINS. CONTACT JLG INDUSTRIES, INC. OR THE LOCAL AUTHORIZED JLG REPRESENTATIVE FOR INFORMATION REGARDING SAFETY-RELATED BULLETINS WHICH MAY HAVE BEEN ISSUED FOR THIS PRODUCT.

NOTICE

JLG INDUSTRIES, INC. SENDS SAFETY RELATED BULLETINS TO THE OWNER OF RECORD OF THIS MACHINE. CONTACT JLG INDUSTRIES, INC. TO ENSURE THAT THE CURRENT OWNER RECORDS ARE UPDATED AND ACCURATE.

NOTICE

JLG INDUSTRIES, INC. MUST BE NOTIFIED IMMEDIATELY IN ALL INSTANCES WHERE JLG PRODUCTS HAVE BEEN INVOLVED IN AN ACCIDENT INVOLVING BODILY INJURY OR DEATH OF PERSONNEL OR WHEN SUBSTANTIAL DAMAGE HAS OCCURRED TO PERSONAL PROPERTY OR THE JLG PRODUCT.

For:

- Accident Reporting
- Product Safety Publications
- Current Owner Updates
- Questions Regarding Product Safety
- Standards and Regulations Compliance Information
- Questions Regarding Special Product Applications
- Questions Regarding Product Modifications

Contact:

Product Safety and Reliability Department
JLG Industries, Inc.
13224 Fountainhead Plaza
Hagerstown, MD 21742

or Your Local JLG Office
(See addresses on inside of manual cover)

In USA:

Toll Free: 877-JLG-SAFE (877-554-7233)

Outside USA:

Phone: 240-420-2661
Fax: 301-745-3713
E-mail: ProductSafety@JLG.com

REVISION LOG

Original Issue	- May 25, 2004
Revised	- June 14, 2004
Revised	- December 14, 2004
Revised	- January 24, 2005
Revised	- June 28, 2010
Revised	- February 8, 2017
Revised	- April 4, 2017
Revised	- May 3, 2022

TABLE OF CONTENTS

SECTION - 1 - SAFETY PRECAUTIONS

- 1.1 GENERAL 1-1
- 1.2 APPROVED MODELS 1-1
- 1.3 SAFETY PRECAUTIONS 1-2

SECTION - 2 - WORKPLACE INSPECTION

- 2.1 WORKPLACE INSPECTION 2-1
 - Observe and Obey: 2-1

SECTION - 3 - CONSTRUCTION SPECIFICATIONS AND USE

- 3.1 CONSTRUCTION SPECIFICATIONS..... 3-1
- 3.2 INSTRUCTIONS FOR USE 3-1



NOTES:

Two columns of horizontal lines for writing notes. The left column contains 17 lines, and the right column contains 17 lines.

SECTION 1. SAFETY PRECAUTIONS

1.1 GENERAL

This manual was prepared for properly trained personnel for the cribbing of approved JLG Products. This manual contains requirements that must be followed in order to perform this function.

 **WARNING**

STRICT COMPLIANCE WITH THIS SUPPLEMENTAL MANUAL AS WELL AS THE OPERATION AND SAFETY MANUAL FOR THE SPECIFIC MODEL, ALONG WITH ANY TRAINING REQUIRED BY THE EMPLOYER IS NECESSARY FOR THE SAFE OPERATION OF THIS MACHINE.

1.2 APPROVED MODELS

340AJ	600A	80HX	1100S
40H	600AJ	800A	1100SJ
400S	600S	800AJ	1200SJP
460SJ	600SJ	800S	1250AJP
450A	660SJ	860SJ	1350SJP
450AJ			1500AJP
			1500SJ
			1850SJ

NOTE: *Contact the JLG Parts Department for the appropriate Cribbing Kit for your machine.*

1.3 SAFETY PRECAUTIONS

⚠ WARNING

FAILURE TO READ, UNDERSTAND AND OBEY ALL WARNINGS AND INSTRUCTIONS PROVIDED IN THIS MANUAL AND THE APPROPRIATE OPERATOR'S MANUAL WILL RESULT IN DEATH OR SERIOUS INJURY.

- Do not operate this machine until complete training is performed by authorized persons.
- Operators must be trained in the safe use of aerial lifts on cribbing, using the information contained in this supplemental manual, and in the applicable Operation and Safety Manual for the particular JLG Product.

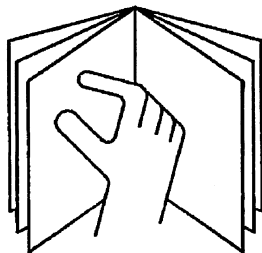

- Be sure that the ground conditions are able to support the maximum load shown on the decals located on the frame of the machine or call JLG Industries for the maximum load.
- Do not raise the platform or drive with the platform elevated unless the machine is on firm, level, smooth surface
- When driving, always position the boom over the rear axle in line with the direction of travel. Remember, if the boom is over the front axle, steer and drive functions will be reversed.
- Do not use cribbing that is not built to the specifications outlined in this manual.
- Do not use cribbing on any JLG products other than those models approved in this manual.

SECTION 1 - SAFETY PRECAUTIONS

- Do not use cribbing on a surface that is not firm (capable of supporting the weight of the machine without cribbing).
- Do not crib machines that are on a slope greater than 5° (9%).
- Do not raise the boom above horizontal unless the machine has been leveled with the cribbing.
- Do not drive the machine on cribbing with the platform raised.

- Do not use cribbing over a hole, depression or bump in the supporting surface.

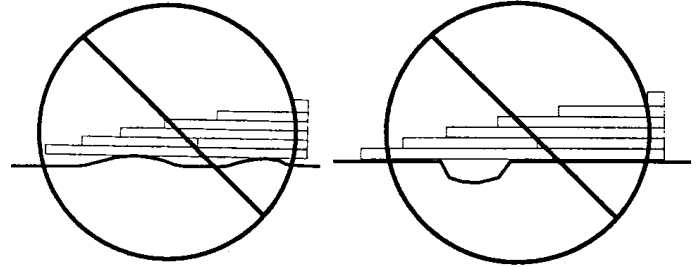

- Only crib two wheels on the same side or on one end. Do not use cribbing in two directions.
- Do not raise the platform when wind speeds may exceed 28 mph.

SECTION 2. WORKPLACE INSPECTION

2.1 WORKPLACE INSPECTION

Observe and Obey:

Read, understand and obey the instructions and hazards in the Workplace Inspection section of the Operation and Safety Manual on your machine.

Conduct a workplace inspection prior to constructing and using cribbing to determine if the site is suitable for safe machine operation.

The workplace must be inspected before each use to determine if any changes have occurred that could affect the safe operation of the machine.

Be aware of and avoid the following hazardous situations when using cribbing:

- Unstable surfaces that could shift under cribbing;
- Surfaces that cannot support the cribbing (refer to the ground bearing pressure specifications in the applicable Service Manual);
- Slippery surfaces that could cause cribbing to slide or skid;
- Sloped surfaces of greater than 5 degrees;
- Drop-offs or holes;
- Raised ground, bumps, or uneven surfaces.

SECTION 3. CONSTRUCTION SPECIFICATIONS AND USE

3.1 CONSTRUCTION SPECIFICATIONS

- Cribbing is to be constructed from APA certified plywood sheets.
- Each plywood sheet must be a minimum of 3/4 inch thick.
- Each plywood sheet must be a minimum of 24 inches by 24 inches.
- Plywood sheets must be layered together with a minimum of 24 inches of overlap for joints.
- Layers are to be secured with 6D ring shank nails, placed a minimum of 8 inches on-center edge and face. Use 8d ring shank nails for plywood over 1 1/8 inches thick.
- Each end of the cribbing is to have a chock that extends the full width of the cribbing. The chock must be a minimum of 6 inches by 6 inches.
- Ramps are to be constructed in a series of steps. Each step shall be a minimum of 12 inches long.
- The maximum total ramp height when cribbing one end shall not exceed 8 inches. The maximum total ramp height when cribbing one side only shall not exceed 6 inches.

- Make sure that machine wheels have a 24 inch square surface or twice the tire width, whichever is larger, to rest on when the platform is elevated.
- When cribbing one side only, the minimum length for the top surface shall be at least equal to the wheelbase +24 inches or twice the tire width, whichever is larger.
- Cribbing must not be constructed to accommodate turns or curves.
- Check the cribbing material for cracks, pitch pockets, dry rot, or knots which can weaken the wood and cause uneven compression. Do not use any wood which exhibits these features.

3.2 INSTRUCTIONS FOR USE

1. Make sure you are properly trained in the use of aerial lifts on cribbing using the information provided in this manual.
2. Make sure the JLG aerial work platform has been modified with a DRIVE/STEER DISABLE lock-out switch that disables the drive/steer function. This switch will be located on or near the ground controls, depending on the model of your machine.

SECTION 3 - CONSTRUCTION SPECIFICATIONS AND USE

NOTE: If the machine does not have a lock-out switch, contact the JLG Parts Department to order a switch installation kit.

- Place the cribbing on a surface that complies with the requirements of this manual and the illustration below.
- With the machine in the stowed position, drive onto the cribbing. The base of the machine must be level on the cribbing. Both tires must be centered upon the cribbing, not off to one side.
- Move the DRIVE/STEER DISABLE switch to lock out the drive/steer function. Ensure the lockout light is illuminated if equipped.

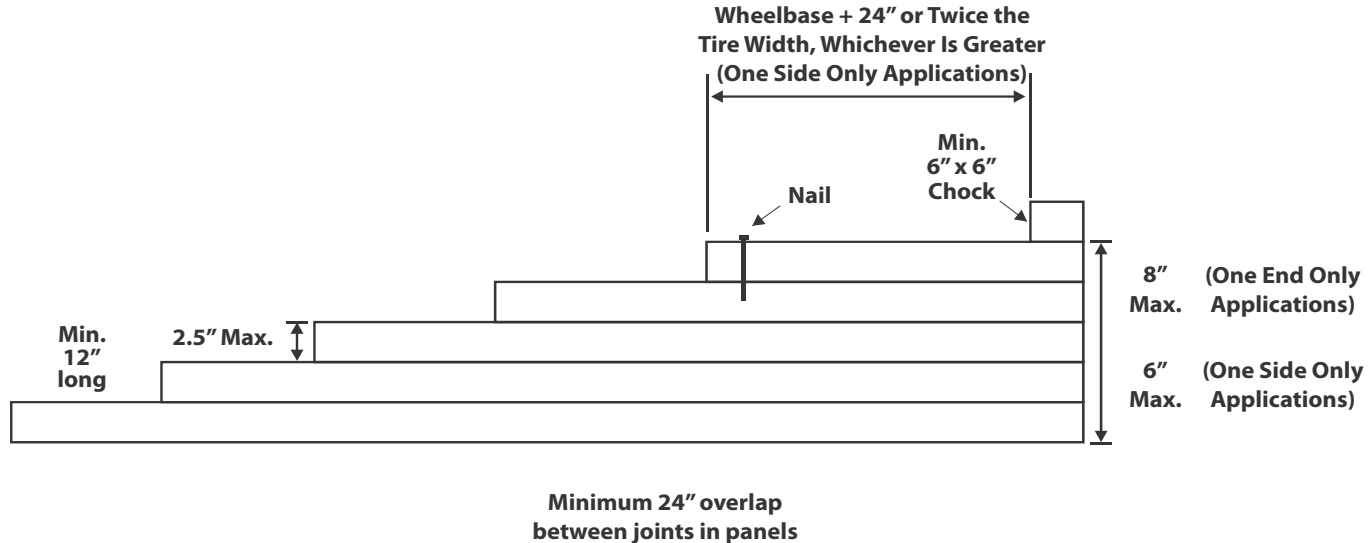

SECTION 3 - CONSTRUCTION SPECIFICATIONS AND USE

- 6.** Ensure the drive and steer functions are disabled prior to elevating the platform by carefully attempting to drive off the cribbing in the direction opposite of the chock.
- 7.** Operate the machine lift function according to the instructions in the appropriate Operation and Safety Manual.
- 8.** When completed, position the boom in the stowed position.
- 9.** Move the DRIVE/STEER DISABLE switch to engage the drive/steer function.
- 10.** With the machine in the stowed position, drive off the cribbing.

SECTION 3 - CONSTRUCTION SPECIFICATIONS AND USE

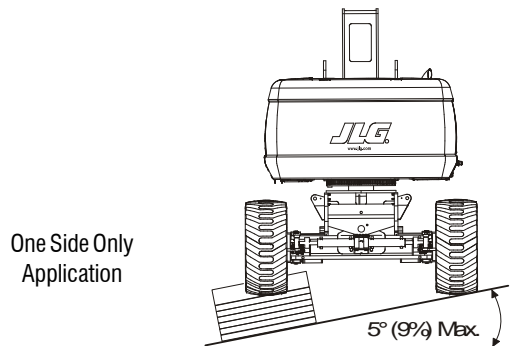
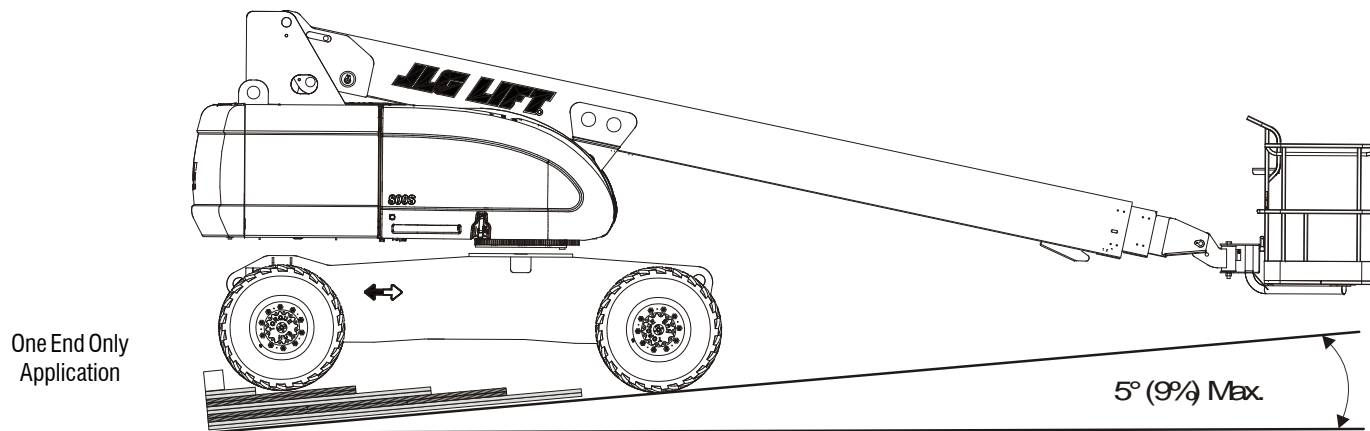



WARNING:



The engine exhaust from this product contains chemicals known to the State of California to cause cancer, birth defects, or other reproductive harm.

1702961

CALIFORNIA PROPOSITION 65 BATTERY WARNING

Battery posts, terminals and related accessories contain lead and lead compounds, chemicals known to the State of California to cause cancer and reproductive harm.

**WASH HANDS
AFTER HANDLING !**



An Oshkosh Corporation Company

JLG Industries, Inc.
1 JLG Drive
McConnellsburg PA. 17233-9533
USA

(717) 485-5161 (Corporate)
 (877) 554-5438 (Service)
 (717) 485-6417
www.jlg.com



3128168

JLG Worldwide Locations

JLG Industries
358 Park Road
Regents Park
NSW 2143
Sydney 2143
Australia
 +6 (12) 87186300
 +6 (12) 65813058
Email: techservicesaus@jlg.com

JLG Ground Support Oude
Bunders 1034
Breitwaterstraat 12A
3630 Maasmechelen
Belgium
 +32 (0) 89 84 82 26
Email: emeaservice@jlg.com

JLG Latino Americana LTDA
Rua Antonia Martins Luiz, 580
Distrito Industrial Joao Narezzi
Indiaatuba-SP 13347-404
Brasil
 +55 (19) 3936 7664 (Parts)
 +55(19)3936 9049 (Service)
Email: comercialpecas@jlg.com
Email: servicios@jlg.com

Oshkosh-JLG (Tianjin) Equipment
Technology LTD
Shanghai Branch
No 465 Xiao Nan Road
Feng Xian District
Shanghai 201204
China
 +86 (21) 800 819 0050

JLG Industries Dubai
Jafza View
PO Box 262728, LB 19
20th Floor, Office 05
Jebel Ali, Dubai
 +971 (0) 4 884 1131
 +971 (0) 4 884 7683
Email: emeaservice@jlg.com

JLG France SAS
Z.I. Guillaume Mon Amy
30204 Fauillet
47400 Tonniens
France
 +33 (0) 553 84 85 86
 +33 (0) 553 84 85 74
Email: pieces@jlg.com

JLG Deutschland GmbH
Max Planck Str. 21
27721 Ritterhude - Ihlpohl
Germany
 +49 (0) 421 69350-0
 +49 (0) 421 69350-45
Email:german-parts@jlg.com

JLG Equipment Services Ltd.
Rm 1107 Landmark North
39 Lung Sum Avenue
Sheung Shui N. T.
Hong Kong
 + (852) 2639 5783
 + (852) 2639 5797

JLG Industries (Italia) S.R.L.
Via Po, 22
20010 Pregnana Milanese (MI)
Italy
 +39 (0) 2 9359 5210
 +39 (0) 2 9359 5211
Email: ricambi@jlg.com

JLG EMEA B.V.
Polaris Avenue 63
2132 JH Hoofddorp
The Netherlands
 +31 (0) 23 565 5665
Email: emeaservice@jlg.com

JLG NZ Access Equipment & Services
2B Fisher Crescent
Mt Wellington 1060
Auckland, New Zealand
 +6 (12) 87186300
 +6 (12) 65813058
Email:techservicesaus@jlg.com

JLG Industries
Vahutinskoe shosse 24b.
Khimki
Moscow Region 141400
Russia Federation
 +7 (499) 922 06 99
 +7 (499) 922 06 99

Oshkosh-JLG Singapore Technology
Equipment Pte Ltd.
35 Tuas Avenue 2
Jurong Industrial Estate
Singapore 639454
 +65 6591 9030
 +65 6591 9045
Email: SEA@jlg.com

JLG Iberica S.L.
Trapadella, 2
Pol. Ind. Castellbisbal Sur
08755 Castellbisbal Barcelona
Spain
 +34 (0) 93 772 47 00
 +34 (0) 93 771 1762
Email:parts_iberica@jlg.com

JLG Sverige AB
Enkopingsvagen 150
176 27 Jarfalla
Sweden
 +46 (0) 8 506 595 00
 +46 (0) 8 506 595 27
Email: nordicsupport@jlg.com

JLG Industries (UK) Ltd.
Bentley House
Bentley Avenue
Middleton, Greater Manchester
M24 2GP
United Kingdom
 +44 (0) 161 654 1000
 +44 (0) 161 654 1003
Email: ukparts@jlg.com